

**Easy** setup

**Dependable** operation

**Economical** quality



Complete Livestock Weighing System  
 Fits Standard Alleyways

5,000 lb capacity in 1 lb increments

**New TS-700 WB Digital Indicator**

- Intelli-hold™ for improved animal weighing
- Totalizing for total weight of multiple animals
- PC compatible for record keeping

**Alleyway Weighing System by Triner Scale**

- WEATHER PROOF
- ADJUSTABLE FEET
- QUICK & EASY SETUP
- DETACHABLE CABLES
- BUILT IN RECHARGEABLE BATTERY
- LOCKS IN ANIMAL'S WEIGHT



Height-adjustable feet for quick, easy leveling



Quick-connect cables



Socket cover caps protect connectors



End cap design eliminates raw edges



5,000 lb capacity in 1 lb increments

**NEW!**

# ALLEYWAY SYSTEM

Livestock Scale by Triner Scale

# TRINER SCALE

"Accurate Around the World Since 1897"

## SPECIFICATIONS

### Alleyway

- Heavy duty aluminum construction
- Diamond aluminum plate surface
- 90" (L) x 26" (W) x 8.25" (H)
- Shipping weight: 80 lbs

### Weigh Bars

- Capacity: 5,000 lb x 1 lb
- Four premium, NTEP approved, Legal for Trade alloy steel nickel plated loadcells
- Loadcells are watertight for indoor/outdoor operation
- Loadcell capacity is 2 times the scale capacity
- Built in overload protection
- 15' quick connecting cables (2)
- Shipping weight: 25 lbs each

### Digital Indicator

- NEMA 4X watertight stainless steel construction
- NTEP approved, Legal for Trade
- Bright easy-to-read backlit LCD display
- Simple operation
- FUNCTIONS:
  - Hold (auto or manual)
  - Totalizing
  - lb/kg Conversion
  - TARE/Gross
  - Printer and PC Compatible
- Tilt adjustable bracket for wall mount or desk mount
- Operates on 110 VAC or internal battery
- Internal rechargeable battery operates 20+ hours
- 120 VAC power/charging adapter
- Shipping weight: 5 lb

### Optional Accessories

- Printer
- Indicator stand

### Complete System Includes

- Aluminum livestock alleyway
- 25" 5,000 lb weigh bars (2)
- Digital indicator & AC adapter
- 15 ft. cables from bars to indicator (2)
- Masonry anchor bolts (4)
- Platform bolts (4)

Aluminum Livestock Alleyway

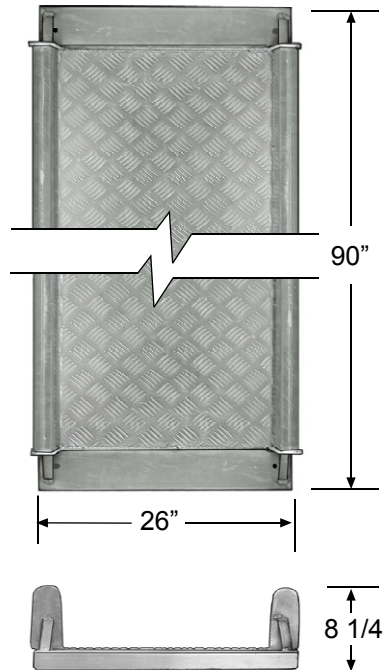

AWB-5 Alleyway Weigh Bars (2)

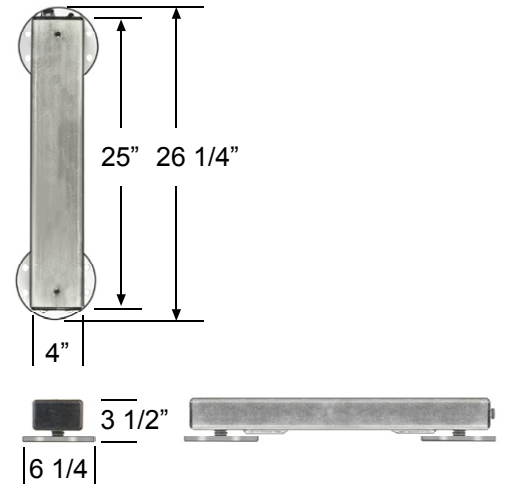

TS-700 WB Weigh Bar Digital Indicator

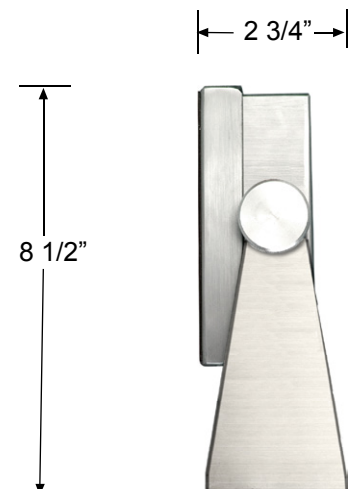
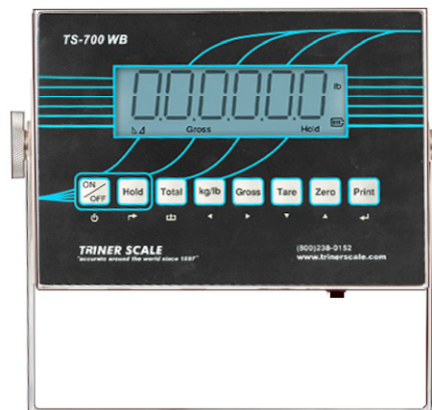
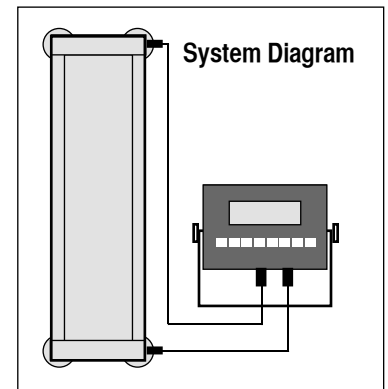
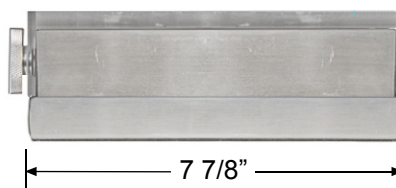

Triner Scale and Manufacturing Company, Inc.  
Toll Free: (800) 238-0152  
Tel: (662) 890-2385 Fax: (662) 890-2386  
[www.trinerscale.com](http://www.trinerscale.com)