

**Reliable** performance  
**Economical** precision weighing  
**Durable** construction

**NEW!**

- BENCH SCALE SERIES FROM TRINER SCALE
- AVAILABLE IN THREE SIZES & TWO CAPACITIES
- DATALOG PC COMPATIBLE

**Model TBS-2424**

- 1,000 lb x 0.2 lb
- 24" x 24"

**Model TBS-1616**

- 250 lb x .05 lb
- 16" x 16"



NTEP Approved  
 Legal for Trade

**Model TBS-1212**

- 250 lb x .05 lb
- 12" x 12"

## TBS Series Bench Scales by Triner Scale

- TUBULAR STEEL FRAME**
- CHECKWEIGHING FUNCTION**
- MAXIMUM WEIGHT HOLD**
- FOUR OVERLOAD STOPS**
- SUPER-BRIGHT LED READOUT**
- STAINLESS STEEL PLATFORM**

NEW!

# TBS Series

Bench Scales from Triner Scale



NTEP Approved  
Legal for Trade

## TRINER SCALE

"Scales for Business and Industry Since 1897"

### SPECIFICATIONS

#### General

- NTEP approved, Legal For Trade
- Stainless steel platform
- All steel tubular frame
- Adjustable, lockable leveling feet
- Leveling bubble
- Checkweighing function with Over, Under, and OK icons
- Hold options:
  - Manual hold
  - Auto hold
  - Peak Hold
- Selectable kg/lb
- Super-bright LED display
- RS-232 interface for connecting to printer, remote display or PC

#### Technical

- Keys
  - On/Off
  - Hold
  - Total
  - kg/lb
  - Gross
  - Tare
  - Zero
  - Print (sends data to printer or PC)
- Status displayed for:
  - Center of Zero
  - Stable
  - Gross
  - Net
  - Tare
  - Total
  - Hold
  - lb
  - kg
  - Hi/Ok/Lo (checkweigh)
- Operating Parameters
  - AC Power: 100 - 250V
  - Operating Temperature:
    - 10° C - +40° C
- Includes 110 VAC adapter
- Shipping Weight:
  - TBS-1212 = 24 lbs
  - TBS-1616 = 33 lbs
  - TBS-2424 = 81 lbs

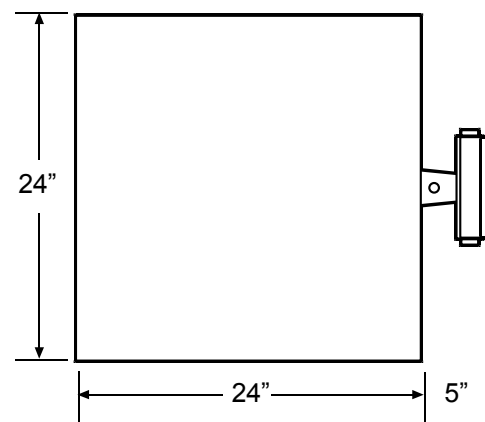
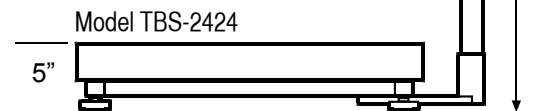
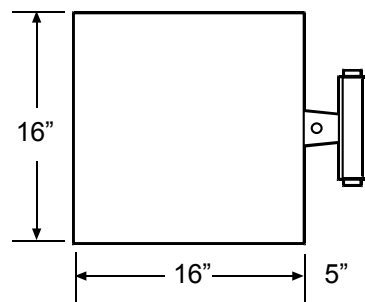
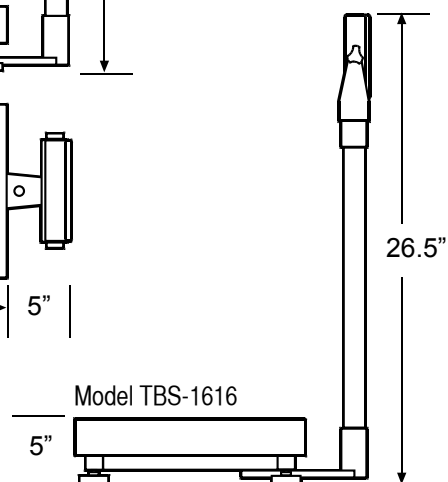
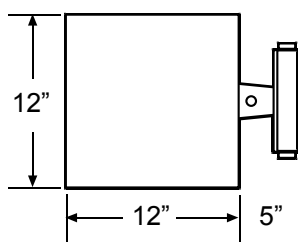
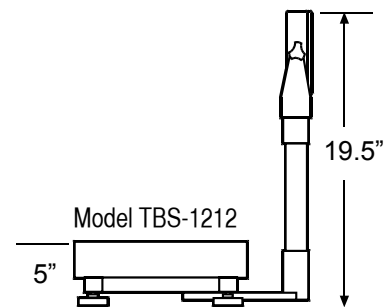

#### RS-232 Output Options

- Ticket Printer
- Remote Display
- Record weigh data to PC (Triner DataLog PC software compatible)

Triner Scale and Manufacturing Company, Inc.  
Toll Free: (800) 238-0152  
Tel: (662) 890-2385 Fax: (662) 890-2386  
[www.trinerscale.com](http://www.trinerscale.com)